

BAS-364E

BAS-366E

BAS-370E

BAS-375E

Programmable Electronic Pattern Sewer



Specifications

		BAS-364E	BAS-366E	BAS-370E	BAS-375E
Machine head		Lock stitch double rotary hook long arm machine			
Rotary hook		Double			
Needle		DP × 17, MR			
Stitch length		0.05 – 12.7 mm			
Max. sewing speed	Intermittent feed mode	2,000 rpm (Max. stitch length: 3mm)			
	Continuous feed mode	3,200 rpm (Max. stitch length: 3mm)			
Max. pattern size (X - Y)		420 × 400 mm	650 × 400 mm	800 × 400 mm	1,200 × 400 mm
Max. number of stitches		20,000 / 1 pattern			
Work clamp stroke		Max. 50 mm			
Intermittent lift stroke		16 mm			
Test function		Operation test function provided for use with low speed drive			
Safety device		Automatic stop function for activation in the event of misoperation realized with intermediate stop function and safety circuits.			
Machine dimensions (mm) (W × D × H)		1,625 × 1,100 × 1,868	1,625 × 1,557 × 1,868	1,625 × 1,820 × 1,868	1,625 × 2,620 × 1,868
Data storage method		3.5 – floppy disc 2HD / 1.44 MB, 2DD			
Power supply		Three phase 220V, 380V, 400V 1KVA			
Motor		AC servo motor 750W			
Air pressure		0.5 Mpa 1.8l / min.			
Weight		400 kg		600 kg	

BAS-364E-0□

(420 x 400 mm)

Application	
1	Heavy materials
2	Medium materials
A	Air bag

BAS-366E-0□

(650 x 400 mm)

Application	
1	Heavy materials
2	Medium materials

BAS-370E-0□

(800 x 400 mm)

Application	
1	Heavy materials
2	Medium materials

BAS-375E-0□

(1,200 x 400 mm)

Application	
1	Heavy materials
2	Medium materials

Option parts

[BAS-364E, 366E, 370E, 375E]

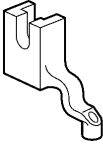
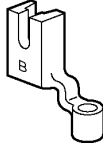
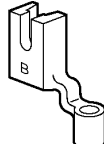
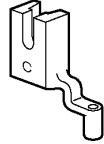
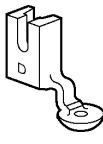
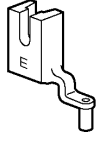
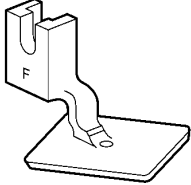
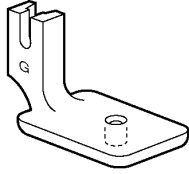
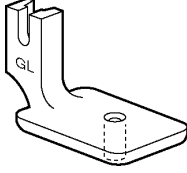
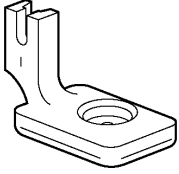
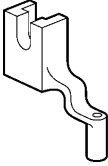
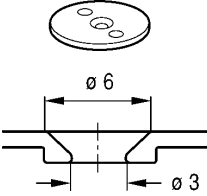
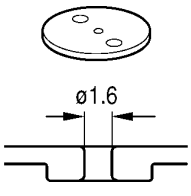
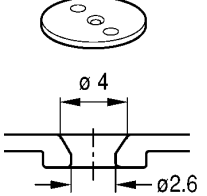
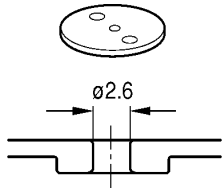
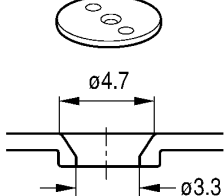
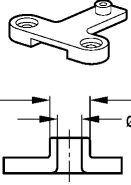
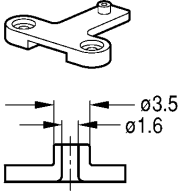
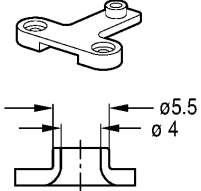
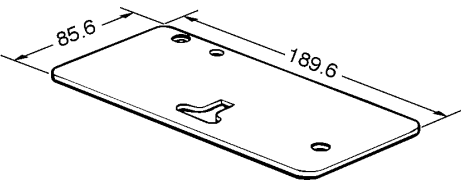
Presser foot, A-cut S40214-001 (φ2.5)	Presser foot, B 152636-101 (φ4)	Presser foot, B-L S49448-001 (φ4)	Presser foot, C 152637-001 (φ2)	Presser foot, D 154069-001 (φ3)
				
Presser foot, E 154089-001 (φ1.6)	Presser foot, F 157237-001 (φ2)	Presser foot, G 158592-001 (φ2)	Presser foot, GL S20864-001 (φ2.5)	Presser foot, I S04887-001 (φ2.5)
				
Presser foot, J S13815-001 (φ2.5)				
				
Needle hole plate, 3 S40215-001(φ3)	Needle hole plate, A 156149-001 (φ1.6)	Needle hole plate, E 156153-001 (φ2.6)	Needle hole plate, F 156154-001 (φ2.2)	Needle hole plate, L S25110-001 (φ3.3)
				
Bottom plunger, A 157795-101 (φ2.5)	Bottom plunger, B 157796-101 (φ1.6)	Bottom plunger, C S05137-101(φ4)		
				
Bottom needle plate S16725-000				
				

Option parts

[BAS-364E, 366E, 370E, 375E]

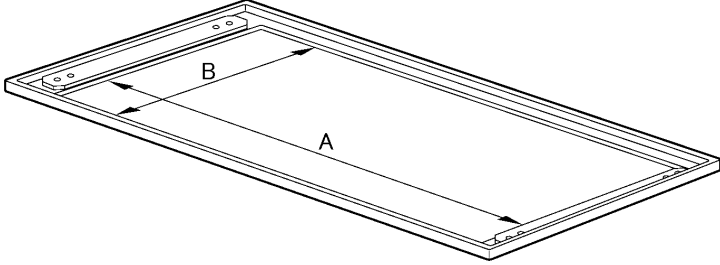
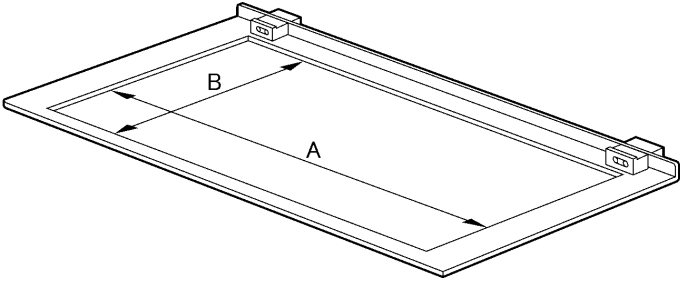
	Work clamp assy, S A=500 B=410 S37380-001
	Work clamp assy, L A=730 B=410 S37836-001
	Cassette plate assy, S A=440 B=410 S37378-001
	Cassette plate assy, L A=670 B=410 S37837-001

Option parts

[BAS-364E, 366E, 370E, 375E]

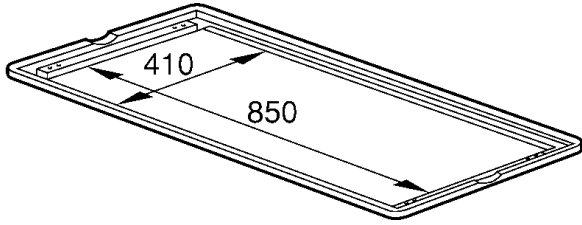
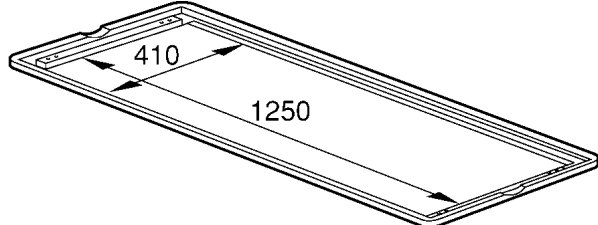
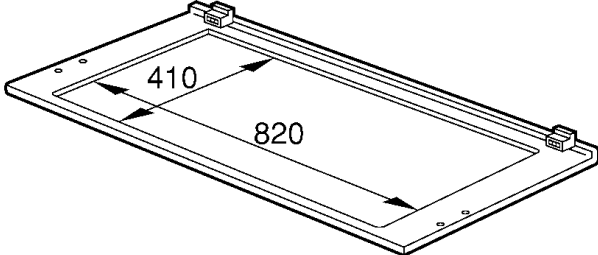
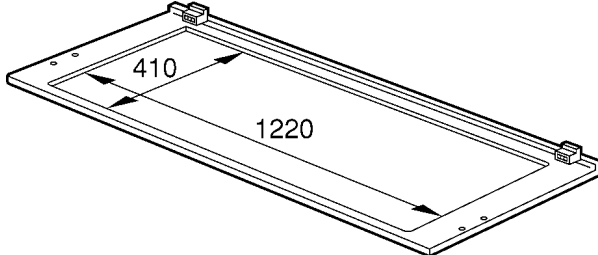
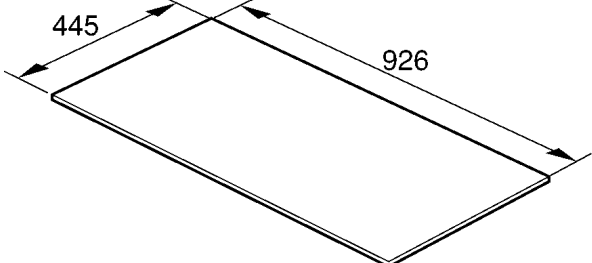
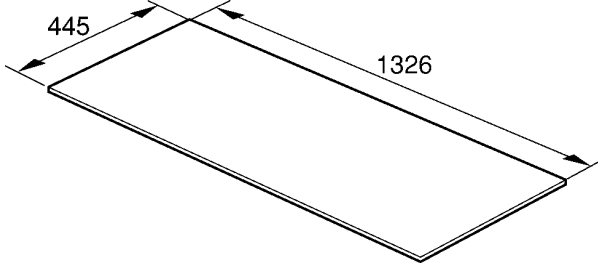
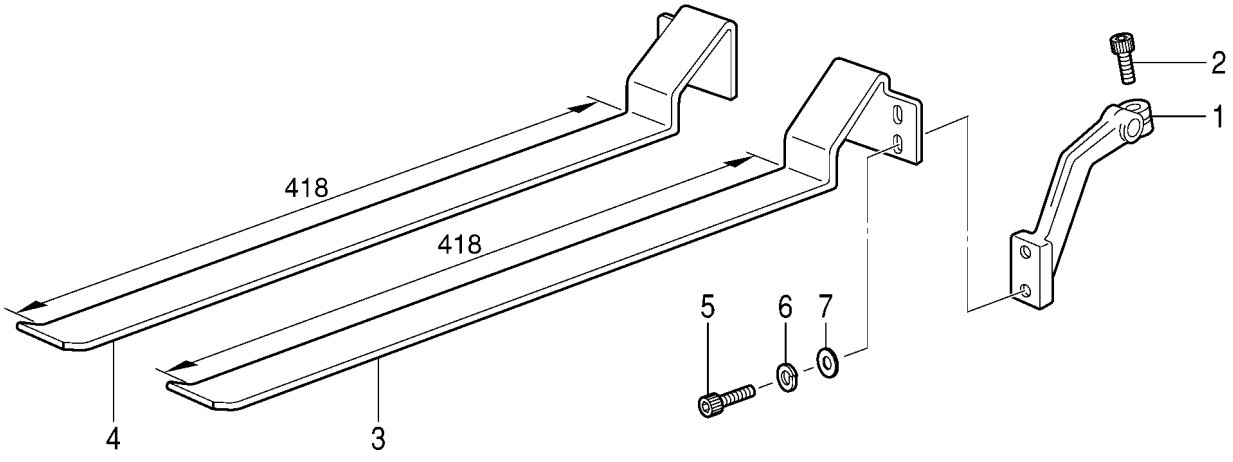
<p>Work clamp assy, S S16868-001</p>	<p>Work clamp assy, L S16869-001</p>
	
<p>Cassette plate assy, S S16789-001</p>	<p>Cassette plate assy, L S16746-001</p>
	
<p>Clamp plate lower, S1 / S16818-000 [T=1] Clamp plate upper, S1 / S16819-000 [T=1] Clamp plate lower, S2 / S29693-000 [T=2] Clamp plate upper, S2 / S29694-000 [T=2]</p>	<p>Clamp plate lower, L1 / S16750-000 [T=1] Clamp plate upper, L1 / S16751-000 [T=1] Clamp plate lower, L2 / S29691-000 [T=2] Clamp plate upper, L2 / S29692-000 [T=2]</p>
	
<p>1. Cloth clamp lever / S16763-009 2. Bolt 5 × 14 / 018501-436 3. Sub-presser (R) / S16934-001 4. Sub-presser (L) / S16933-001 5. Bolt 5 × 12 / 018501-236 6. Spring washer 2-5 / 028050-246 7. Plain washer 5 / 025050-236</p>	
	

Option parts

Thread tension (For 2-step thread tension)

[BAS-364E, 366E, 370E, 375E]

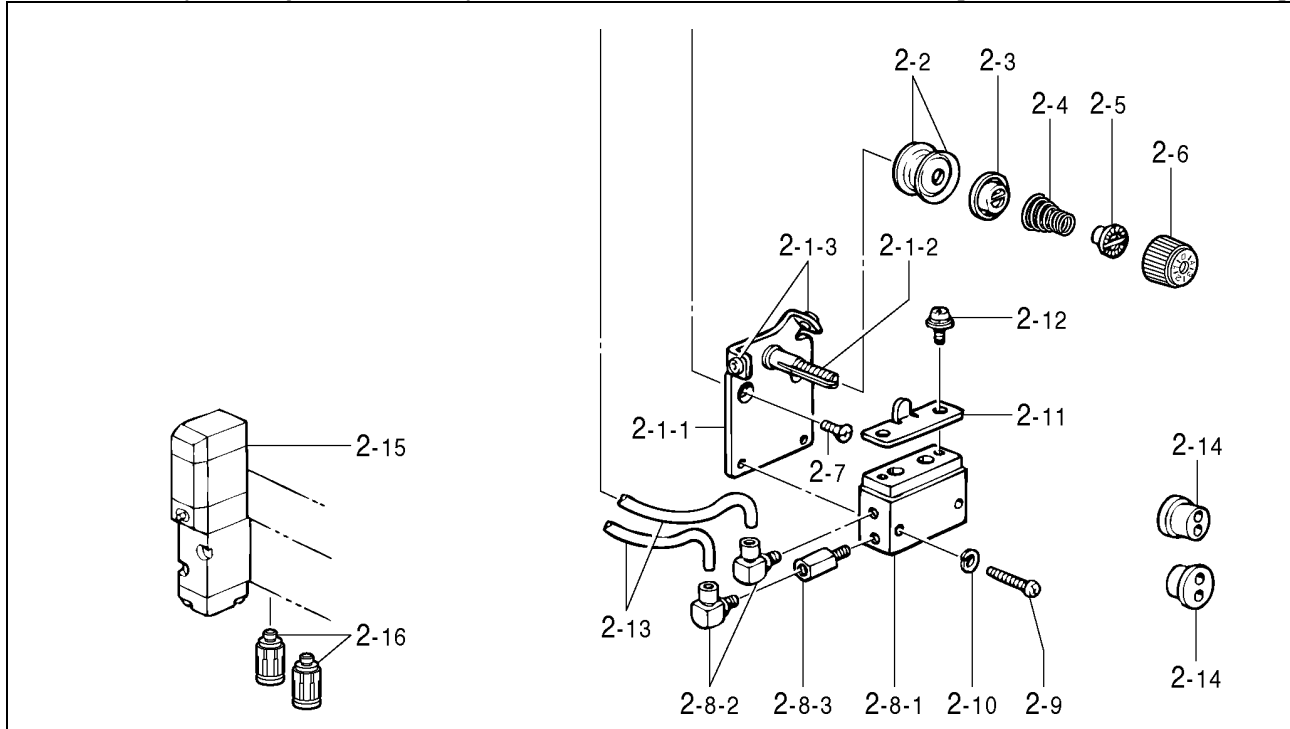

Ref. No.	Part name	Part code	Q'ty
2	2-step thread tension assy	S29416-001	1
2-1	Thread tension assy	S24927-101	1
2-1-1	Cylinder support plate	S24928-101	1
2-1-2	Tension stud, L	S07485-001	1
2-1-3	Thread bush	146924-000	2
2-2	Tension disc	145446-001	2
2-3	Disc presser, tension	159805-001	1
2-4	Tension spring	148851-001	1
2-5	Flange washer, ; T-spring	144105-000	1
2-6	Tension nut	S31032-001	1
2-7	Screw, flat M4 × 8	004400-814	2
2-8	Twin rod cylinder assy	S30004-000	1
2-8-1	Twin rod cylinder	S12103-000	1
2-8-2	Tube elbow, M - 5HL - 4	S12150-000	2
2-8-3	Extended joint M - 5J	S24930-000	1
2-9	Screw, pan M4 × 20	062402-016	2
2-10	Washer, spring 2 - 4	028040-243	2
2-11	Countersink claw	S24931-001	1
2-12	Screw, pan (S/P washer) M4 × 8	052400-806	2
2-13	Air tube, L = 3250	S11440-002	2
2-14	Cord bush	146020-009	2
2-15	Solenoid valve	S29696-000	1
2-16	Half union, ;Q4M5	S18415-101	2

Option parts
Manual switch mechanism

[BAS-364E For air bags]

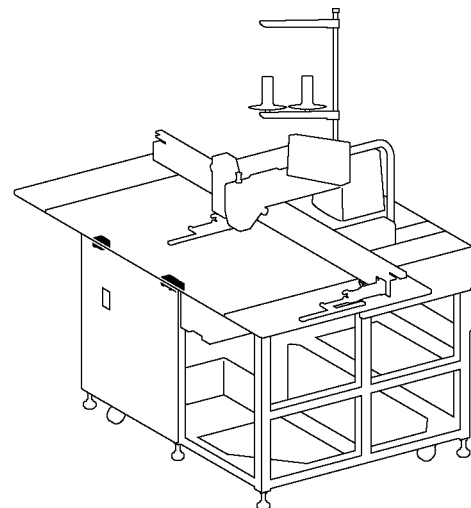
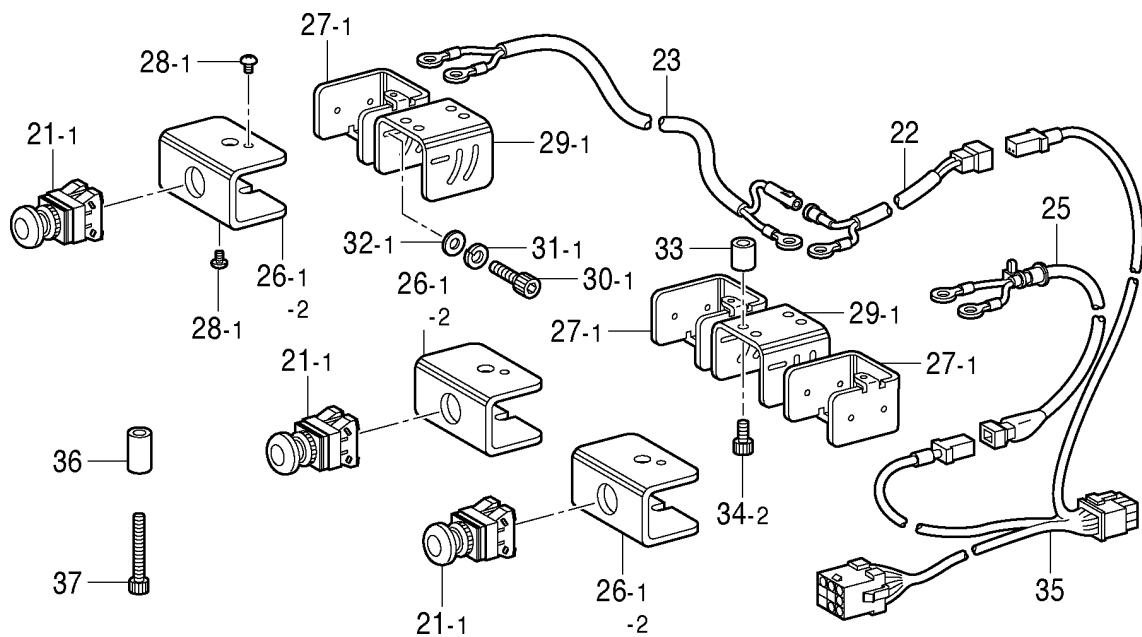

Ref. No.	Part name	Part code	Q'ty
<For BAS-364E air bag specifications>			
21-1	SW-ABS310N ; green (Mushroom type)	S11750-102	2
22	Hand switch harness, A	S17012-000	1
23	Hand switch harness, B	S17013-000	1
24-1	SW-ABS310N, yellow (Mushroom type)	S11750-100	1
25	EM harness	S24185-000	1
26-1	EM-switch holder	S24184-009	3
26-2	EM-switch holder	S24184-009	2
27-1	EM switch holder plate	S33524-009	3
28-1	Screw, truss M4 × 8	008400-804	6
29-1	Switch bracket	S33525-001	2
30-1	Bolt, socket M5 × 12	018501-236	6
31-1	Washer, spring 2 – 5	028050-246	6
32-1	Washer, plain M5	025050-236	6
33	Spacer	S31909-001	4
34-2	Bolt, socket M4 × 8	018400-836	4
35	Foot switch harness, B	S17015-000	1
36	Spacer	S37384-001	4
37	Bolt, socket M4 x 40	018404-036	4

Option parts
Manual switch mechanism

[BAS-364E For air bags]

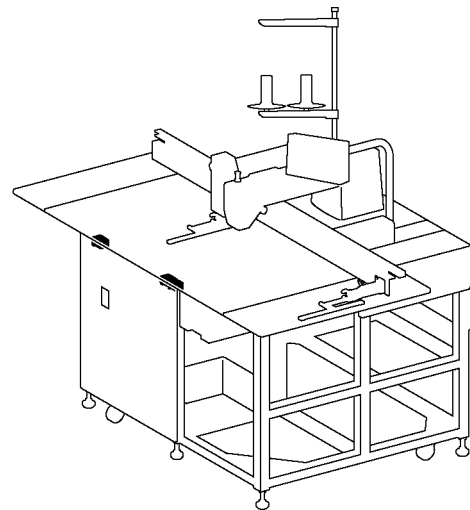
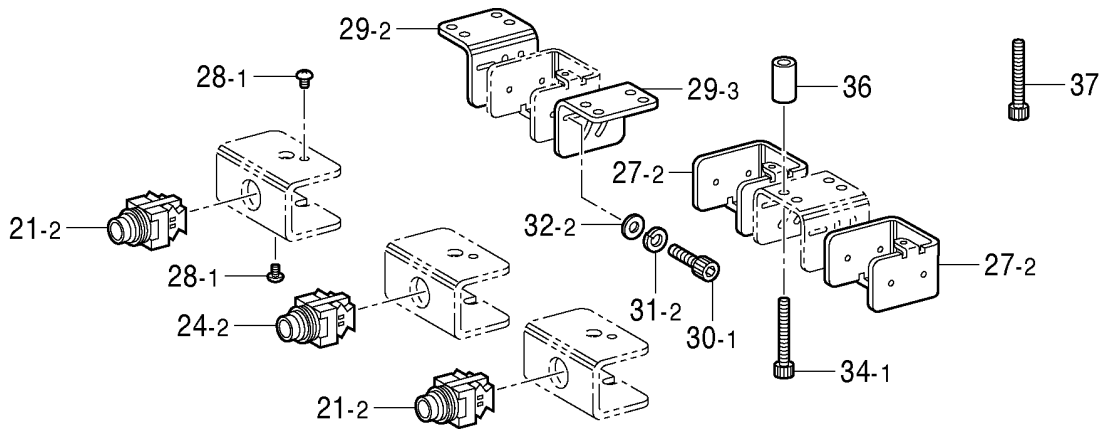

Ref. No.	Part name	Part code	Q'ty
	<For BAS-364E air bag specifications>		
21-2	Switch, ABFS210N; green (with guard)	S17030-001	2
24-2	Switch, ABFS210N; yellow (with guard)	S17030-002	1
27-2	EM-switch holder plate	S33524-009	2
28-2	Screw, truss M4 x 8	008400804	4
29-2	Switch bracket, right	S33526-001	1
29-3	Switch bracket, left	S33527-001	1
30-2	Bolt, socket M5x12	018501-236	4
31-2	Washer, spring 2-5	028050-246	4
32-2	Washer, plain M5	025050-236	4
34-1	Bolt, socket M4 x 20	018402-036	4
36	Spacer	S37384-001	4
37	Bolt, socket M4 x 20	018404-036	4

Option parts

Presser foot lifter mechanism

[BAS-364E For air bags]

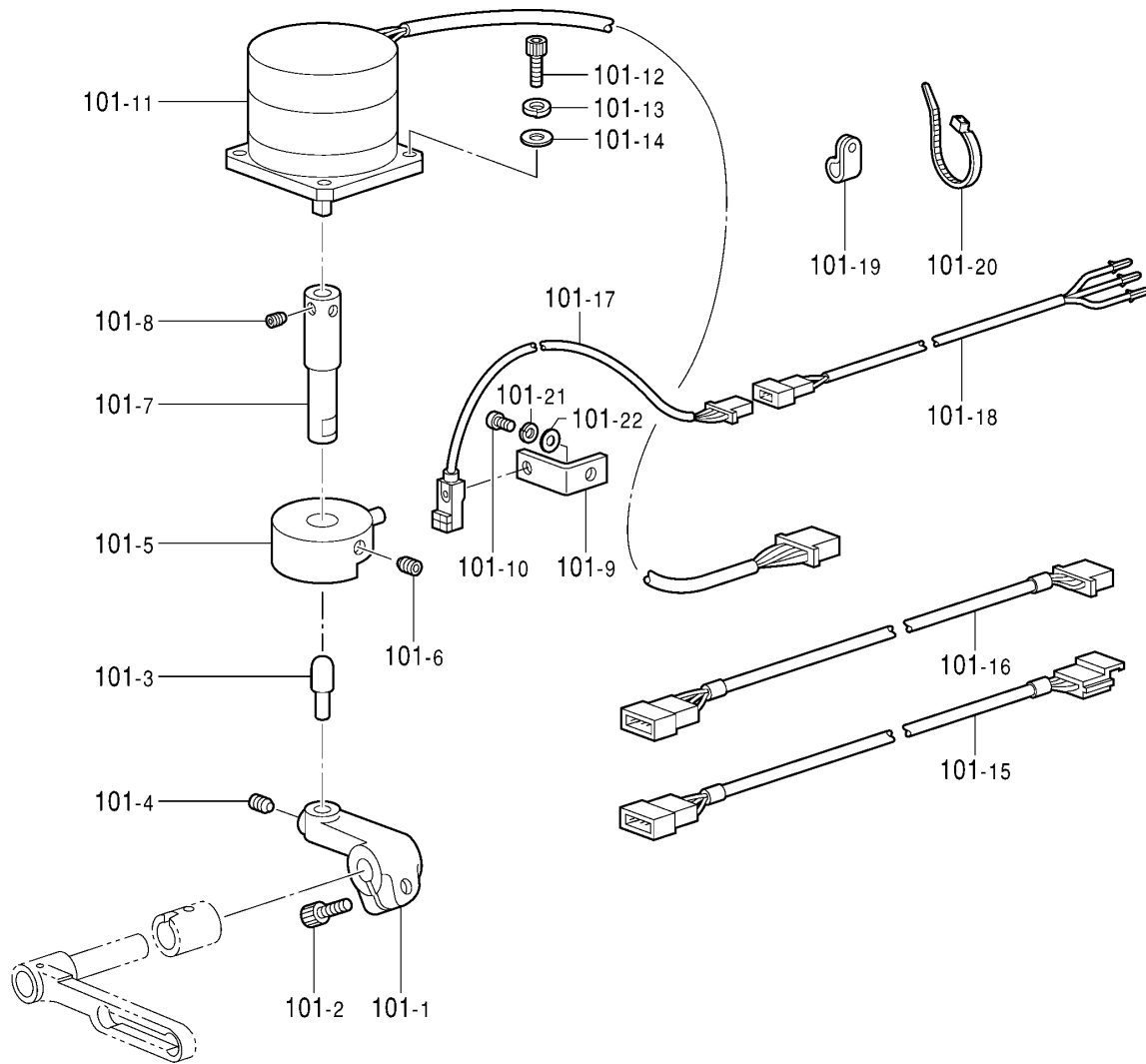

Ref. No.	Part name	Part code	Q'ty
101	Work clamp control assy	S52661-001	1
101-1	Stopper arm	S16989-001	1
101-2	Bolt, socket M6 × 16	018061-622	1
101-3	Stopper	S16940-001	1
101-4	Set screw, socket (CP) SM4.76	014710-522	1
101-5	Work clamp control cam assy	S30025-001	1
101-6	Set screw, socket (FT) M5 × 5	012500-536	1
101-7	Control cam shaft	S16888-001	1
101-8	Set screw, socket (FT) M4 × 3.2	S23452-001	2
101-9	Setting plate, hole sensor	S16950-001	1
101-10	Screw, pan M3.57-40 × 8	062670-812	1
101-11	Pulse motor, ; BH-200575042-B04	Z25701-001	1
101-12	Bolt, socket M4 × 12	018401-222	4
101-13	Washer, spring 2-4	028040-242	4
101-14	Washer, plain S 4	025040-132	4
101-15	Pulse motor harness, A	S52640-000	1
101-16	Pulse motor harness, B	S20099-000	1
101-17	Hole sensor	S20083-000	1
101-18	Head sensor harness, C	S20068-000	1
101-19	Cord holder, 5N	S00480-000	1
101-20	Band PLT1M	S04557-000	2
101-21	Washer, spring 2-3.5	028350-242	1
101-22	Washer, plain S 4	025040-132	1

Option parts
Bottom mechanism

[BAS-364E, 366E, 370E, 375E]

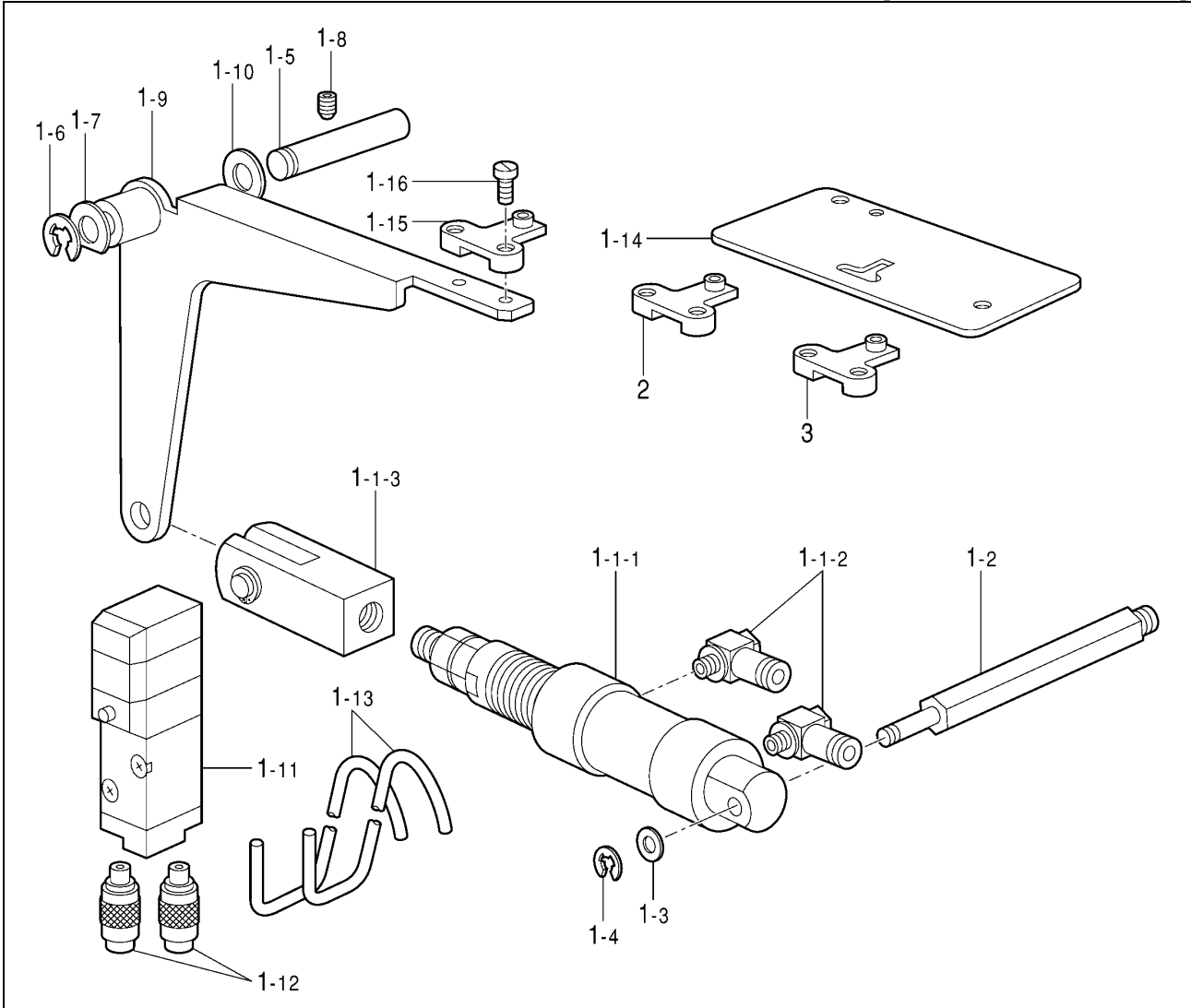

Ref. No.	Part name	Part code	Q'ty
1	Bottom assy, w/solenoid valve	S37397-201	1
1-1	Bottom cylinder assy	S16893-100	1
1-1-1	Cylinder	S16903-100	1
1-1-2	Elbow, M5	S41271-000	2
1-1-3	Bracket, Y-type	S16936-000	1
1-2	Cylinder support shaft	S16902-001	1
1-3	Washer, plain M6	025060-232	1
1-4	Retaining ring, E4	048040-342	1
1-5	Belt shift bar	141574-001	1
1-6	Retaining ring, E7	048070-342	1
1-7	Washer, plain special 8	110367-001	1
1-8	Set screw, socket (FT) M6 x 6	012060-636	1
1-9	Bottom lever	S16905-101	1
1-10	Washer	153596-001	1
1-11	Solenoid valve	S29696-000	1
1-12	Half union, ;Q4M5	S18415-101	2
1-13	Air tube 4L = 1300	S18387-004	2
1-14	Bottom needle plate	S16725-000	1
1-15	Bottom plunger, A	157795-101	1
1-16	Screw, M3.18 - 44 x 6.5	100080-003	2
2	Bottom plunger, B	157796-101	1
3	Bottom plunger, C	S05137-101	1